

Tilak Maharashtra University

Diploma in Engineering

SUB: CNC

Assignment No: I

(Write any five)

Q.1 Give advantage of CNC

Q.2 Application of Numerical control

Q.3 Advantage & disadvantage of NC

Q.4 Describe Basic components of an NC system

Q.5 Describe The NC procedure

Q.6 Describe NC co-ordinate system

Q.7 Describe NC Motion control system

Assignment No: II

(Write any five)

Q.1 What are type of statement in APT language

Q.2 Write down the general form of the statement

1 geometry statement

2 motion statement

3 post processor statement

4 Auxiliary statement

Q.3 Short notes on Machine control unit (MCU)

Q.4 Describe Tape coding & format

Q.5 Describe the steps in computer assisted part programming

Q.6 Describe in brief with neat sketch ,ISO card & EIA Card

Q.7 Write down the some function of G code & M code

Assignment No: III

(Write any five)

Q.1 What is absolute positioning & Incremental positioning

Q.2 Differentiate between manual part programming & Assisted part programming

Q.3 Write note on Basic hardware structure of a digital computer

Q.4 Types of memory

Q.5 Preparation of Manuscript And program for drilling operation 10m

The part Preparation of Manuscript And program for drilling operation 10m is shown in the figure & use the following information

1 use metric system of program

2 use incremental system of dimensioning

3 use word address format

Machine tool format is;

N3 G2 X3.3 Y3.3 R3.3 Z3.3 F2 M2 EOB

Where

N3 – Sequence number function

G2- Preparator function

X3.3- Dimension specification format in X-direction

Y3.3 -- direction Dimension specification format in Y-

R3.3- clearance point specification format

Z3.3- direction Dimension specification Format in z direction

F2 – Feed rate function

M2- Miscellaneous function

EOB- End of block function

Supposing drill point is at 3mm above the surface of part & part is of 20mm Thickness

Refer fig No -1

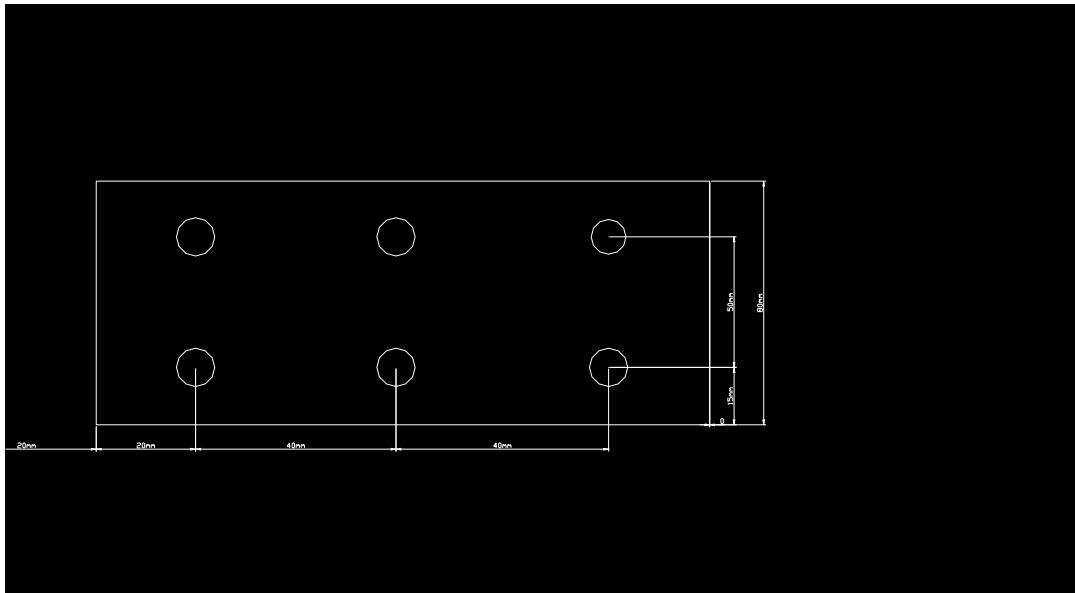

Q.6 Prepare a complete APT Program for the work piece shown the work part , material a plane low carbon steel plate cut out in the rough shape . The tool is a two flute 8mm in diameter H.S.S end Milling cutter. Typical cutting conditions

Cutting speed = 600 RPM

Feed rate = 4 cm/min

Refer fig No-2

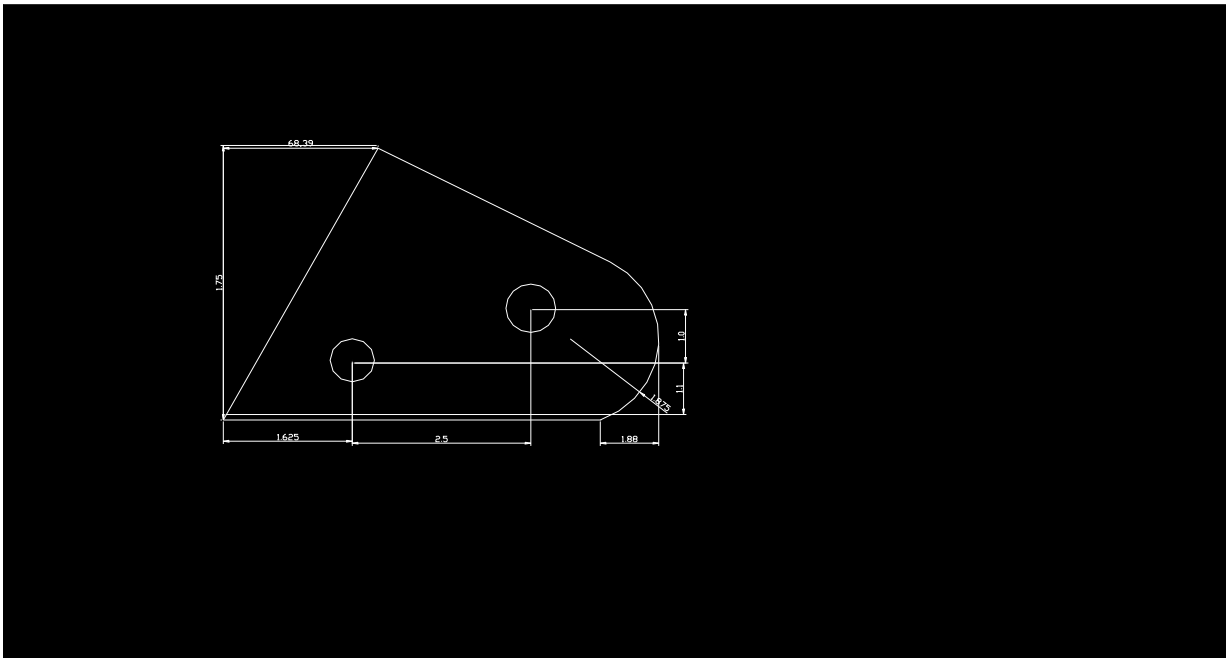

Write CNC program

Refer fig No-3

